

> Dimensions (mm) and weight (kg)

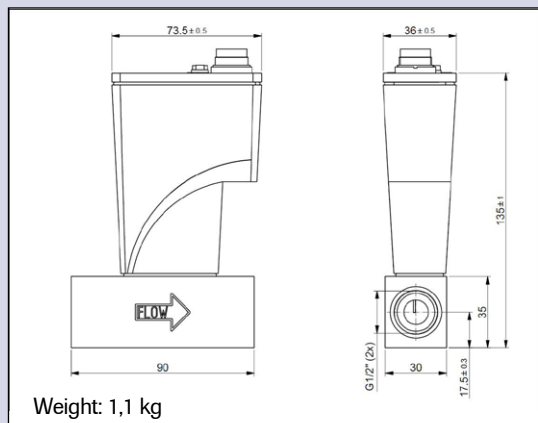

Dimension table adapters (RS-type)

Compression type	1/2" BSSPP	
	Size	A
adapter 12 mm OD	33.5	
adapter 1/2" OD	33.5	
adapter 20 mm OD	36.5	
adapter 3/8" OD	30.7	
Face-seal	1/2" BSSPP	
	Size	A
adapter 1/2" inlet	27.6	

Compression type

Face-seal

*) Dimension A is typical finger-tight.

> Options and accessories

<ul style="list-style-type: none"> - Free software support for operation, monitoring, optimizing or to interface between digital instruments and windows software. 	
<ul style="list-style-type: none"> - BRIGHT compact local Readout/Control module - E-5700 / E-7000 Power Supply 	
<ul style="list-style-type: none"> - Interconnecting cables for power and analog/digital communication - PiPS Plug-in Power Supply 	
<ul style="list-style-type: none"> - Optional ATEX Zone 2 Cat. 3 protection. Hereto we will furnish extra cover(s) for mechanical impact protection (see pictures), including applicable certificate(s). 	

> Alternatives

<ul style="list-style-type: none"> - IN-FLOW^{CTA} direct (no by-pass) Mass Flow Meter model T12 (flow capacities from 5 up to 50 l_r/min Air-equivalent Full Scale) - IN-FLOW^{CTA} direct (no by-pass) Mass Flow Meter model T14 (flow capacities from 100 up to 1000 l_r/min Air-equivalent FS) 	
<ul style="list-style-type: none"> - LOW-ΔP-FLOW series (by-pass style) Mass Flow Meter for low pressure drop applications or corrosive gas service 	

XXXXXXXXXXXXXXXXXXXX

XXXXXXXXXX
 XXXXXXXX
 XXXXX
 DXXXXXXXXXX

XXXXXXXXXX
 DXXXXXXXXXX
 XXXXX
 GXXXXXX

XXXXXXXXXXXX
 XXXXX
 XXX
 XXXXXXXXX

XXXXXX
 XXXXXXXXX
 XXXXXX
 XXXXX

XX
 XXXXX