

> Dimensions (mm) and weight (kg)

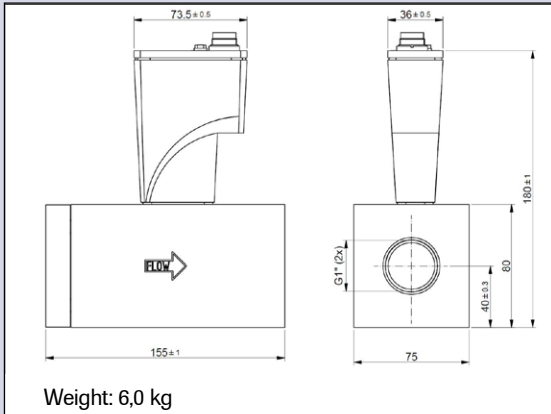

Dimension table adapters (RS-type)

Compression type	1"BSPP	
	Size A	
adapter 25 mm OD	41.7	
adapter 1" OD	41.7	

Compression type

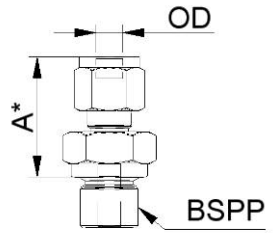

*) Dimension A is typical finger-tight.

> Options and accessories

<ul style="list-style-type: none"> - Free software support for operation, monitoring, optimizing or to interface between digital instruments and windows software. 	
<ul style="list-style-type: none"> - BRIGHT compact local Readout/Control module - E-5700 / E-7000 Power Supply 	
<ul style="list-style-type: none"> - Interconnecting cables for power and analog/digital communication - PiPS Plug-in Power Supply 	
<ul style="list-style-type: none"> - Optional ATEX Zone 2 Cat. 3 protection. Hereto we will furnish extra cover(s) for mechanical impact protection (see pictures), including applicable certificate(s). 	

> Alternatives

<ul style="list-style-type: none"> - IN-FLOW^{CTA} direct (no by-pass) Mass Flow Meter model T14 (capacities from 100 up to 1000 l_n/min Air-equivalent Full Scale) 	
<ul style="list-style-type: none"> - LOW-ΔP-FLOW series F-106Z (by-pass style) Mass Flow Meter for low pressure drop applications or corrosive gas service (capacities up to 1000 m³_n/h Air-equivalent) 	

XXXXXXXXXXXXXXXXXXXXXXXXXXXX

XXXXXXXXXX
XXXXXXXXXX
XXXXXX
XXXXXXXXXX

XXXXXXXXXX
XXXXXXXXXX
XXXXXXXXXX
XXXXXXXXXX

XXXXXXXXXXXX
XXXXXX
XXXX
XXXXXXXXXXXX

XXXXXX
XXXXXXXXXX
XXXXXX
XXXXXX

: bronkhorst.pro-solution.ru | : brk@pro-solution.ru
: 8 800 511 88 70